

Model KBF PRO 720 | Constant climate chambers with expanded temperature / humidity range

A powerful all-rounder among constant climate chambers: Equipped with all kinds of sophisticated technology, the KBF PRO takes any material test in its stride – whether it takes place at -20°C or under THB conditions at +85°C and 85% relative humidity. It offers flexible water supply options for all installation sites and consumes up to 40% less energy than its predecessor, the KMF model. Optional light modules are also available to turn the KBF PRO into a chamber for ICH photostability testing or plant growth.

BENEFITS

- Reliable and powerful thanks to innovative temperature control technology
- Reliable: failsafe operation over the long term thanks to proven compressor technology and inner chamber made of stainless steel
- Smart: signal triangle with light-up status display, ergonomic control terminal with touchscreen program controller, rack with telescopic rails
- Efficient: low energy consumption thanks to modern inverter cooling technology



Model 720



Model 720

IMPORTANT FEATURES

- Temperature range: -20 °C to +100 °C
- Humidity range: 10% to 98% RH
- Proven APT.line™ preheating chamber technology
- Up to 40% lower energy consumption compared to the previous model
- Energy-efficient cooling with modern inverter cooling unit
- Cooling with climate-neutral R-290 refrigerant
- Door heating to prevent condensation
- Adjustable fan speed
- Humidity regulation with capacitive humidity sensor and responsive steam humidification
- Sturdy housing design with HIT sandwich technology
- Stainless-steel inner chamber
- Inner doors made of metal oxide-coated safety glass
- Two racks made of stainless steel with telescopic rails
- 80 mm x 45 mm access port with silicone plug
- Floor-standing units featuring sturdy twin casters with brakes at the front
- Intuitive touchscreen controller with time-segment and real-time programming
- Ergonomically adjustable operating terminal
- Signal triangle with light-up status display
- Internal data logger, measured values can be read out in open format via USB
- Class 3.3 independent temperature safety device (DIN 12880) with visual and acoustic alarms
- Unit self-test for comprehensive status analysis
- Data interfaces: Ethernet, USB
- BINDER Multi Management Software APT-COM™ basic edition
- Optional light modules for ICH photostability tests
- Optional LED light modules for plant growth

ORDERING INFORMATION

Interior volume [L]	Power supply - unit fuse	Plug*	Version	Model version	Art.-No.
Model KBF PRO 720					
727	208...240 V 1~ 50/60 Hz -16,0 A	CEE 7/7	Standard	KBFP720-230V	9020-0442

TECHNICAL DATA

Data	
Article Number	9020-0442
Designation	KBFPRO720-230V
Option model	Standard
Performance Data Temperature	
Temperature range	-20...100 °C
Max. heat compensation at 40°C	1,000 W
Performance Data Climate	
Temperature range with humidity	10...90 °C
Humidity range	10...98 % RH
Temperature uniformity at 25°C and 60% RH	0.3 ± K
Temperature uniformity at 40°C and 75% RH	0.3 ± K
Temperature fluctuation at 25°C and 60% RH	0.1 ± K
Temperature fluctuation at 40°C and 75% RH	0.1 ± K
Humidity fluctuation at 25°C and 60% RH	1 ± % RH
Humidity fluctuation at 40°C and 75% RH	1 ± % RH
Recovery time after door was opened for 30 s at 25°C and 60% RH	2 min
Recovery time after door was opened for 30 s at 40°C and 75% RH	5 min
Electrical data	
Rated Voltage	208...240 V
Power frequency	50/60 Hz
Nominal power	1,8 kW
Unit fuse	16,0 A
Phase (Nominal voltage)	1~
Dimensions and weights	
Interior volume	727 L
Net weight of the unit (empty)	312 kg
Load per rack	40 kg
Permitted load	200 kg
Wall clearance back	180 mm

Wall clearance sidewise	180 mm
Housing dimensions not incl. fittings and connections	
Width net	1,285 mm
Height net	1,951 mm
Depth net	900 mm
Internal Dimensions	
Interior width	1,011 mm
Interior height	1,250 mm
Interior depth	575 mm
Inner doors	2
Unit doors	2
Environment-specific data	
Sound-pressure level at 25°C and 60% RH	50 dB(A)
Energy consumption at 25°C and 60% RH	390 Wh/h
Energy consumption at 40°C and 75% RH	435 Wh/h
Energy consumption at 85°C and 85% RH	600 Wh/h
Fixtures	
Number of shelves (std./max.)	2/16

All technical data is specified for unloaded units with standard equipment at an ambient temperature of +22 °C ±3 °C and a power supply voltage fluctuation of ±10 %. The temperature data is determined in accordance to BINDER factory standard following DIN 12880, observing the recommended wall clearances of 10 % of the height, width, and depth of the inner chamber. Technical data refers to 100 % fan speed. All indications are average values, typical for units produced in series. We reserve the right to change technical specifications at any time.

DIMENSIONS Incl. fittings and connections [mm]

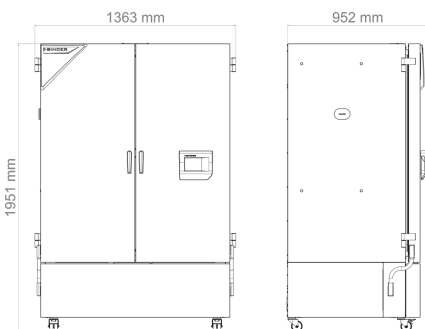

DIAGRAMS

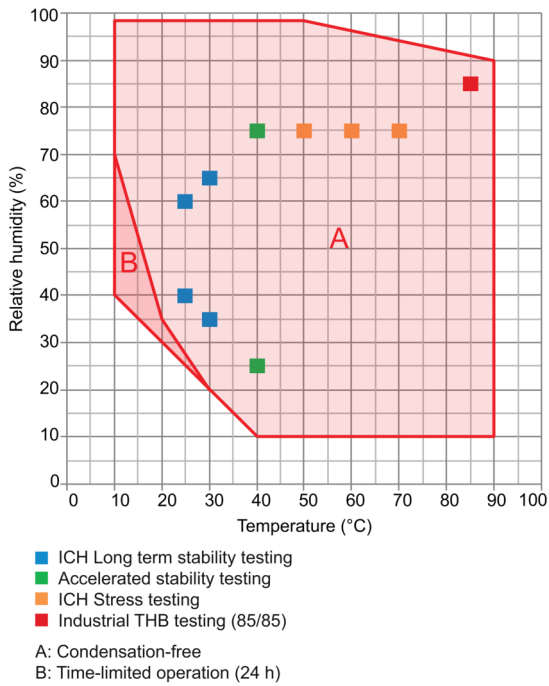

Climate chart

OPTIONS

Designation	Description	*	Art.-No.
	left		
	30 mm	01	8012-2489
	50 mm	01	8012-2490
	100 mm	01	8012-2491
	right		
	30 mm	01	8012-2492
Access port with silicone plug	50 mm	01	8012-2493
	100 mm	01	8012-2494
	top		
	30 mm	01	8012-2500
	50 mm	01	8012-2495
	100 mm	01	8012-2496
Alarm output, zero-voltage	accessible via 3-pin clamping sleeve (max. 24 V - 2.5 A)	-	8012-2504
Analog output 4-20 mA	for temperature and humidity values (output not adjustable)	-	8012-2375

Designation	Description	*	Art.-No.
Calibration certificate, expanded	for temperature and humidity; for extending the measurement in center of chamber to include another test value	-	8012-2576
Calibration certificate, temperature	temperature measurement incl. certificate, 9 measuring points at specified temperature	-	8012-2379
	temperature measurement incl. certificate, 15- 18 measuring points at specified temperature	-	8012-2383
	temperature measurement incl. certificate and 27 measuring points at specified temperature	-	8012-2427
Calibration certificate, temperature and humidity	Measurement in center of chamber at 25°C / 60% RH or at specified test values	-	8012-2438
	temperature (according to DIN12880) and humidity measurement incl. certificate, 27 temperature measuring points and 1 humidity measuring point, at 25 °C / 60 % RH or at specified values	-	8012-2578
Coated heat exchanger	For preventing damage to the aluminum heat exchanger caused by corrosive sample material	-	8012-2585
Door lock	lockable door handle	-	8012-2539
Door lock, electromechanical	can be opened with PIN code via controller	-	8012-2590
Inner chamber, reinforced	permitted load with U rails 300 kg	-	8012-2527
Interior lighting	With climate-resistant LEDs, switches when the unit door is opened	-	8012-2566
Shipping pallet	with unloading ramp for installing unit without forklift	-	8012-2548
Specimen temperature display	Flexible Pt 100 indoor temperature sensor, for object temperature display or control	-	8012-2554
Swivel casters, height-adjustable	For horizontal alignment of the unit on uneven floors	-	8012-2544

ACCESSORIES

Designation	Description	*	Art.-No.
APT-COM™ 4 GLP-Edition	for working under GLP-compliant conditions. Measured values are documented in a tamper-proof way in line with the requirements of FDA Regulation 21 CFR 11.		
	version 4, GLP edition	-	9053-0042
APT-COM™ 4 PROFESSIONAL-Edition	convenient unit and user management built on the BASIC edition. Suitable for networking up to 100 units.		
	version 4, PROFESSIONAL edition	-	9053-0040
BINDER PURE AQUA SERVICE	System for preparation or complete desalination of tap water, complete set containing PURE AQUA 300 single-use cartridge, measuring device, and all necessary connecting parts	-	8012-0759
BINDER PURE AQUA SERVICE, accessories	Single-use, replacement cartridge for BINDER PURE AQUA System	-	6011-0165
Converter, voltage	to operate the device at a nominal voltage of 120 V 1 ph 60 Hz		
	240 V option model	-	8009-0821
CO ₂ gassing module	BINDER CO ₂ gassing module 0-1%, with NDIR CO ₂ sensor and analog output 4-20 mA	-	8012-2140

Designation	Description	*	Art.-No.
	BINDER CO ₂ gassing module 0-20%, with NDIR CO ₂ sensor and analog output 4-20 mA	-	8012-2138
ICH light module	BINDER ICH-Q1B light module consisting of a VIS cassette and a UVA cassette as well as an independent power supply	-	8012-2442
ICH light module with LQC	BINDER ICH-Q1B light module with light-dose control consisting of a VIS cassette, a UVA cassette, a spherical VIA sensor, a spherical UVA sensor as well as an independent power supply	-	8012-2444
LED light bars	Basic set consisting of 2 pieces, attachment material, control unit for max. 4 light strips, 100-240 V, 50/60 Hz		
	Basic set 500, length 50 cm	-	8012-1108
	Basic set 900, length 90 cm	-	8012-1109
	Expansion set consisting of 2 pieces, attachment material: clips. For expanding the basic set of light bars		
	Expansion set 500, length 50 cm	-	8012-1717
	Expansion set 900, length 90 cm	-	8012-1718
Light module for plants	BINDER LED plant light module consisting of 16 LED strip lights, 3-channel controller and fresh air pump as well as independent power supply	-	8012-2439
pH-neutral detergent	concentrated, for gentle remove of residual contaminants; 1 kg	-	8012-2250
Qualification documents	IQ/OQ/PQ documents – supporting documents for validation performed by customers, according to customer requirements, PQ section added to qualification folder IQ/OQ; parameters: temperature and humidity values		
	Digital in PDF format	-	7057-0006
	Hard copy inside folder	-	7007-0006
	IQ/OQ documents – supporting documents for validation performed by customers, consisting of: IQ/OQ checklists incl. calibration guide and comprehensive unit documentation; parameters: temperature and humidity values		
	Digital in PDF format	-	7057-0002
	Hard copy inside folder	-	7007-0002
Reinforced rack	Shelf rack in set with pair of retaining rails (U rails), made entirely of stainless steel		
	Load-bearing capacity 80 kg	-	8012-2414
Shelf rack, perforated	Shelf rack in set with pair of retaining rails (U rails), made entirely of stainless steel		
	Load-bearing capacity 40 kg	-	8012-2408
Standard rack	Shelf rack in set with pair of retaining rails (ball bearing mounted telescopic rails), made entirely of stainless steel		
	Load-bearing capacity 40 kg	-	8012-2385
	Shelf rack in set with pair of retaining rails (U rails), made entirely of stainless steel		
	Load-bearing capacity 40 kg	-	8012-2391

Designation	Description	*	Art.-No.
Water supply	External, free-standing, set consisting of 20-liter fresh water canister with pump and level sensor and 20-liter waste water canister	-	8012-2592

SERVICES

Designation	Description	*	Art.-No.
Calibration services			
CO ₂ regulation calibration 0-1%	Calibration of CO ₂ concentration at 0,5 % by vol. with analyzed test gas, including certificate	05	DL30-0404
CO ₂ regulation calibration 0-20%	Calibration of CO ₂ concentration at 5,0 % by vol. with analyzed test gas, including certificate	05	DL30-0405
ICH light measurement with certificate	Measurement of irradiance (UVA) and illumination intensity (VIS) at 25 measuring points each, recording of emission spectra for UVA and VIS, including certificate	05	DL30-0530
Temperature and humidity calibration	Expansion –Temperature and humidity calibration with 1 measuring point in center of chamber with 1 specified pair of values, including certificate	05	DL30-0302
	Temperature and humidity calibration with 1 measuring point in center of chamber with 1 specified pair of values, including certificate	05	DL30-0340
Temperature and humidity measurement, 9-1 measuring points	Temperature measurement with 9 temperature measuring points and 1 humidity measuring point in center of chamber with a pair of values specified by the user, including certificate	05	DL30-0309
Temperature and humidity measurement, 18-1 measuring points	Temperature measurement with 18 temperature measuring points and 1 humidity measuring point in center of chamber with a pair of values specified by the user, including certificate	05	DL30-0318
Temperature and humidity measurement, 27-1 measuring points	Temperature measurement with 27 temperature measuring points and 1 humidity measuring point in center of chamber with a pair of values specified by the user, including certificate	05	DL30-0327
Temperature and humidity measurement according to DIN12880	Temperature measurement in accordance with DIN 12880 with 27 temperature measuring points and 1 humidity measuring point in center of chamber with a pair of values specified by the user, including certificate	05	DL30-0427
Installation services			
Installation CO ₂ control module	Installation of the BINDER CO ₂ control module (0-1% oder 0-20%), Mounting the supply box, inserting the CO ₂ sensor and the gas hose into the interior, sealing the access port, connecting the box to an existing CO ₂ gas supply, updating the controller data set, function check	05	DL10-0130
Installation ICH light module	Installation of the BINDER ICH-Q1B light module: Mounting the supply box, installing and connecting the light cassettes, (LQC: and light sensors,) sealing the access port, (LQC: updating the controller dataset,) function check	05	DL10-0140
Installation LED plant light module	Installation of the BINDER LED plant light module, mounting the supply box, mounting the LED light bars on demand, laying the cables and fresh air hose, sealing the access port, function check	05	DL10-0150
Unit commissioning	Connect the unit to the customer-side connections (electricity, water, wastewater, gas), basic functions check, brief operating instructions. (excl.: unpacking, setup, controller instructions, programming, installation work)	05	DL10-0170
Unit instructions	Instruction regarding operating principle and basic functions of the unit, operation of the control electronics including programming	05	DL10-0550
Maintenance contracts			

Designation	Description	*	Art.-No.
BRONZE 3-year maintenance contract	Maintenance service as contractually agreed, visual inspection of mechanical and electrical components, check of control response, 20% discount on spare parts	05	DL20-0710
GOLD 3-year maintenance contract	Maintenance service as contractually agreed, visual inspection of mechanical and electrical components, check of control response, 20% discount on spare parts, testing of all key functions, replacement of wear parts, calibration of one temperature/humidity value, including certificate	05	DL20-0920
SILVER 3-year maintenance contract	Maintenance service as contractually agreed, visual inspection of mechanical and electrical components, check of control response, 20% discount on spare parts, testing of all key functions, calibration of one test temperature specified by the user in the center of the usable space, without certificate	05	DL20-0820
Maintenance services			
Maintenance	One-off maintenance service in accordance with maintenance schedule. Visual inspection of mechanical and electrical components, testing of all key functions. Calibration of a test temperature specified by the user in center of usable space without certificate	05	DL20-0613
Validation services			
Execution of IQ/OQ	Execution of IQ/OQ in accordance with qualification folder	05	DL42-0300
Execution of IQ/OQ/PQ	Execution of IQ/OQ/PQ in accordance with qualification folder	05	DL44-0500
Warranty service			
1-year warranty extension	The warranty is extended by 1 year from the delivery date, wear parts are excluded	05	DL50-0030

NOTES

- 01 Condensation may occur in the area around the access port. Access ports may be placed in custom locations for an additional charge.
- 05 Quoted prices do not include travel costs. Please refer to the chapter on BINDER Service for travel costs for your region. Quoted prices for services performed in Switzerland do not include a country-specific added fee (available on request).

BINDER GmbH

Tuttlingen, Germany
TEL +49 7462 2005 0
info@binder-world.com
www.binder-world.com

BINDER Inc.

Bohemia, NY, USA
TEL +1 631 224 4340
usa@binder-world.com
www.binder-world.us

**BINDER Environmental Testing
Equipment (Shanghai) Co., Ltd.**

Shanghai, P.R. China
TEL +86 21 685 808 25
china@binder-world.com
www.binder-world.com